

# SIMPLE PUMP™

## INSTALLATION PROCEDURE FOR MODEL ADA100 ROTARY HAND PUMP



SIMPLE PUMP COMPANY  
1140 Amarillo Drive, Gardnerville, Nevada 89460-7504  
Phone: 877-492-8711 (toll free) or 775.265.4908  
Mon-Fri: 8am-5pm PST (GMT/UTC -8hours)  
Fax: 888.826.1444 (toll-free)  
[info@simplepump.com](mailto:info@simplepump.com) • [www.simplepump.com](http://www.simplepump.com)

## TABLE OF CONTENTS

Introduction	3
Section 1: How We Shipped the ADA100	4
Section 2: Inspecting the Existing System / Removal of Old Pump	4
Section 3: Replacing The Existing Well Cover.	5
Section 4: Pump Cylinder, Drop Pipe Installation.	5
Section 5: Pump Head Installation.	7
Section 6: Pumping Water. Finishing Touches	9

## INTRODUCTION

---

Thank you for purchasing a Simple Pump. We are extremely proud of the high quality products that we manufacture. We have installed our pumps in a variety of well types and sizes and our instructions are a result of installation experience and input from the USDA-FS-MTDC. Please carefully read through these instructions. Your time will be well spent. At any time, if you think you are overwhelmed, give us a call or get the help of a professional pump installer.

The ADA100 Rotary Hand Pump was developed in concert with the USDA-FS-MTDC in Missoula, Montana. The ADA100 is designed to deliver Safe Drinking Water Act (SDWA - chemical-free) drinking water for the physically-challenged or anyone who cannot operate a lever arm pump due to the high input force required with old-fashioned, cast iron lever arm pumps. ADAAG (14.15.4) defines that an accessible hand pump must be able to be operated with a maximum of 5 lbs. of force and the control height must fall between 28"-40". The axis of rotation of the 6" handle crank must fall 34" above the ground. With the ADA100, the input force required to deliver drinking water in 4-8 ounce increments, from 100 feet, is less than 5 lbs. The access elevation can be adjusted to fall within 28"-40". The design of the pump drive system is intended to be robust allowing for long-term useful life in the outdoors.

We will be referring to parts by their part number and name. Use the attached parts list to identify parts as you read through these instructions.

### ASSEMBLY PARTS LIST

P1	Pumping Cylinder Assembly (SIM040, SIM044, SIM047, SIM043-1, SIM043)
P2	Pump Head (installed in cabinet, SIMA01)
P3	Top Pump Rod (SIM020)
P9	Well Cover (SIMA10-6" or SIM0A14-8")
P10	Taper Flange (SIMA11)
P11	Safety Tool
D1	Standard Drop Pipe
D2	Sucker Rod with male and female fused ends
D3	Sucker Rod Guide
D5	Top Drop Pipe

### REQUIRED TOOLS AND SUPPLIES

3" pocket mirror	One set of Allen wrenches
Cutting torch or reciprocating saw (Sawzall)	Safety tool (P11)
Flat file or hand grinder	Teflon tape
Bleach solution-50% bleach /50% water	Crescent wrench
One pipe wrench	
One pair of channel locks	Two pair of vise grips
Hack saw & PVC cement (may be required)	

## SECTION 1: HOW WE SHIPPED THE ADA100

---

The ADA100 was shipped to you in two containers. The first is a spiral-wound paper tube measuring 108" in length X 7" in diameter, weighing up to 52lbs, containing the 9' drop pipe kits. The weight will vary depending on the number of drop pipe kits. The ends of this tube have been taped and stretch-wrapped to survive the rigors of shipping. The second box is a corrugated shipper measuring 36" x 16" x 12", weighing approximately 90lbs. This box contains the pump cylinder, piston, piston rod, well cap, taper flange, PVC adapter and rotary pump drive system.

## SECTION 2: INSPECTING THE EXISTING SYSTEM / REMOVAL OF OLD PUMP

---

### TOOLS / SUPPLIES NEEDED:

3" pocket mirror, cutting torch or reciprocating hack saw (Sawzall)

In this section you will remove your existing pump and well cover and inspect your well for any obstacles that might obstruct the installation of the ADA100.

- a) Remove your existing well cover. There are so many styles, you will have to figure this one out on your own. It may be necessary to use a cutting torch or reciprocating hack saw to remove the old pump from the casing. When cutting the existing casing, be sure to make your cut at approximately 16 inches from the ground as this will result in a desired final elevation of crank arm drive shaft point of rotation between 32"-36".
- b) Using a mirror reflecting the sun (don't laugh it's the best way), shine down the casing. If you have a straight well, you can see the water reflecting as deep as 200 feet. Now that you have determined that you have a relatively unobstructed path to the water, you can proceed.
- c) In our experience, the most efficient way to remove the existing pump is to contact a local well drilling company. They will have a vehicle equipped with a hoist greatly facilitating the removal of the drop pipe string. The most difficult step in the installation of the ADA100 accessible hand pump is the removal of the existing hand pump. Again, in traditional hand pumps, such as the Monitor pump, galvanized steel drop pipe is used. Therefore, the drop pipe string is very heavy. If the well is relatively shallow, the drop pipe string can be removed by hand. Consult the user's manual for the existing pump for more specific directions on removal. The well driller will also be able to extend or shorten the well casing (tell them your requirements before they get to the site so they bring appropriate equipment). The top of the casing is 16 inches

above ground. They will also be able to make the top of the well casing level if asked. This will ensure that the pump will be perpendicular to the ground upon installation.

**Note:** Due to some adjustability in the pump height, the top of the well casing could fall in a range of 14-18 inches above ground and it will be possible to position the handle shaft at the proper height of 34" above ground level.

## SECTION 3: REPLACING THE EXISTING WELL COVER.

---

### TOOLS / SUPPLIES NEEDED

Flat file or hand grinder

- a) After cutting the casing in Section 2, inspect the outer rim of the well casing. The ADA100 well cover is made to fit a standard 6" pipe. The casing should measure 6-5/8" on the outside diameter. Your new cover has 1/16" clearance. Well drillers often leave torch slag on the casing. This needs to be removed if it protrudes beyond the outside diameter. A sharp flat file will remove it. A hand grinder will also remove the slag very quickly. Make sure the cut is level.
- b) Install the ADA100 well cap to the casing using the four Allen head set screws. The 3/4" male PVC plug in the cover is for water testing access after the ADA100 is in place. The ADA100 well cover incorporates a taper lock design to hold the ADA100 at the proper elevation with approximately 10 inches of height adjustment. The taper lock collar should be installed on the 2 1/4 " O.D. riser tube about 2" up from the bottom of the threads on the riser tube in anticipation of a later assembly step. It may be necessary to use a large flat head screwdriver to slightly pry open the gap in the taper lock collar for easier installation past the male NPT threads.

## SECTION 4: PUMP CYLINDER, DROP PIPE INSTALLATION.

---

In this section we will review the installation of the entire string of new drop pipe with the pump cylinder at the bottom. Be extremely cautious during this sequence...dropping the entire string down the well is easy to do and once dropped they are almost impossible to retrieve. Follow these directions!

### TOOLS / SUPPLIES NEEDED

One pair of channel locks, one pipe wrench, two pairs of vise grips, safety tool (P11), Allen wrench set, Teflon tape, one gallon bleach solution made up of 50% chlorine bleach and 50% water.

Before starting, let's identify and organize the parts that we will need. On the ADA100, the drop pipes are all identical except the one that will be used on the top (D5). This one has male threads on both ends...1" threads on the bottom end, 1-1/4" threads on the top end. A 1/16" diameter weep hole has been drilled at a point three feet down from the top fitting. The weep hole location is marked with magic marker.

- a) Lay out all of your pipes with the capped ends away from you.
- b) Take the pump cylinder (P1) with piston rod male threads protruding and thread on a female sucker rod end. Tighten the sucker rod couplers with two pairs of vice grips. Tighten to the point where the two fittings are shoulder-to-shoulder. Do not over tighten.
- c) Apply Teflon tape and thread the drop pipe into the pump cylinder. Be careful not to cross thread. Hand tighten the PVC drop pipe into the SS body of the pump while holding the pump body with one channel lock or pipe wrench.
- d) Pour the bleach solution over the pump cylinder. (Watch your clothes.)
- e) (two persons) Now stand the assembly on end with the pump cylinder at the bottom, and insert the assembly into the new well cover through the 2-3/4" hole. When the pump passes through the port, slide the safety tool over the pipe and let it lay on the well cover. As the pipe is lowered, the safety tool will stop the drop pipe at the coupling. You can now let go of the drop pipe.
- f) You should be looking at a female coupling with a male sucker rod end protruding about 4". (The piston rod should be pushed to the bottom of the pump cylinder if it is not already there). Now take a sucker rod guide (D3) and slide it over the protruding rod and into the female coupling. Then take a sucker rod with female end and thread this onto the protruding male sucker rod end. Tighten the sucker rod couplers (DO NOT grip on the fiberglass rod) with two pairs of vice grips until the male and female sucker rod couplers are shoulder-to-shoulder. Do not over tighten. Do not crush either the stainless steel fittings or the fiberglass rod.
- g) Take another section of standard drop pipe (D1) and stand on end with the blue plastic cap down. With one person holding the pipe upright over the female coupling in the well cover held in place by the safety tool, the other person can remove the blue plastic cap. Apply Teflon tape and then thread both pieces of drop pipe together making sure they are not cross threaded. Hand tighten the newly-added drop pipe while holding the outside of the female fitting of the already-assembled drop pipe with one pair of vice grips. DO NOT TIGHTEN TO MORE THAN 5/8" OF THREAD ENGAGEMENT OR YOU WILL DISTORT THE ROD GUIDE. Do not let the coupling spin on the safety tool, as it can work its way out. Lift the pipe string while the other person removes the safety tool. As soon as the coupling passes through the port, re-position the safety tool and hold it until the next coupling approaches. As the next coupling nears the safety tool, the other person can grab the sucker rod and pull upward helping to support the load and to keep the other person from pinching his fingers as the coupling comes into contact with the safety tool.

NOTE: This process is repeated for each section of standard drop pipe. When you suspect that you might be near your water level, pull up on the sucker rod at any time. If you are not in the water yet, the rod will fall very quickly. When you are in water, the rod will fall more slowly. Sometimes, as the pipe is lowered, a gurgling sound can be heard when the pump is in water. You can also stroke the rod repeatedly and water will be pumped up the string. If you are in water, it will become harder to stroke after ten strokes or so. The pipe string is also much heavier with water in it.

DO NOT OVER TORQUE THE SECTIONS OF DROP PIPE AS THIS CAN DISTORT THE ROD GUIDE AND CAUSE SEVERE BINDING. THE MALE NPT THREADS ARE TAPERED AND EXCESSIVE TORQUE IS NOT NECESSARY TO PREVENT LEAKAGE. TIGHTEN TO A MAXIMUM OF 5/8" OF THREAD ENGAGEMENT.

- h) When you are ready for the top drop pipe, install it just like the others. A rod guide is required in the top fitting. Linear alignment of the top end of the top sucker rod will be controlled by the 3/4" shaft and the rod gland at the pump head and the last, top rod guide. Lower this drop pipe down to the safety tool just like the others completed so far.

## SECTION 5: PUMP HEAD INSTALLATION.

---

In this section we will review the installation and assembly of the pump head and drive system.

### TOOLS / SUPPLIES NEEDED

One pair of channel locks, two pair of vise grips, crescent wrench, Allen Wrench set, (a hack saw and PVC cement may be required in section c below)

- a) Find the 3/4" diameter top pump rod (P3) and thread it onto the sucker rod at the well cover. Tighten with two pairs of vise grips. Grip the 3/4" rod only at the upper end where flats have been milled for a crescent wrench.
- b) Apply Teflon tape to the male thread at the top of the drop pipe string. Thread the 1-1/4" female end of the 12-1/2" PVC adaptor onto the 1-1/4" male end of the drop pipe string. The female/opposite end of the adaptor has been bushed to 2" to attach to the male/bottom of the 2" riser tube. We have provided a 1-1/4" slip coupler that can be used (if necessary) to shorten the PVC adaptor if for some reason the pump piston is operating too close to the top of the pump cylinder. Two of these adaptors and a short length of 1-1/4" PVC pipe can be used (if necessary) to lengthen the PVC adaptor if for some reason the pump piston is operating too close to the bottom of the pump cylinder.
- c) (two persons) Apply Teflon tape to the 2" male thread on the riser tube. Slide the pump head / cabinet assembly over the 3/4" shaft being careful to guide the 3/4" shaft

through the rod gland mounted inside the pump head which is mounted in the bottom of the cabinet. The cabinet weighs 50lbs...so be careful.

- d) Once the  $\frac{3}{4}$ " rod is inserted through the rod gland (3" is ideal), with a  $\frac{3}{16}$ " Allen wrench, loosely tighten the three Allen head bolts holding the taper flange to the well cover. This is a snug fit. Rotate the assembly counterclockwise if needed to arrive at a final elevation of approximately 34" as measured from the ground to the input crank drive shaft centerline. Snug up the three Allen head bolts to hold the elevation until the final function check.
- e) Install the pre-assembled crank handle, crank arm, drive shaft, bearing housing, counter-weight assembly through the 2-1/8" hole in the cabinet (from the inside-out) with the crank handle leading. Tighten the bearing housing to the cabinet wall using four  $\frac{5}{16}$ "-18 X  $\frac{3}{4}$ " Allen head bolts. Do not cross thread.
- f) After positioning the two cam rollers in the yoke tracks, install the yoke to the  $\frac{3}{4}$ " rod by tightening the  $\frac{3}{4}$ " rod using a crescent wrench (gripping only on the flats of the top end of the rod). A few early models had right-hand threads on the yoke and the  $\frac{3}{4}$ " rod. Later models had left-hand threads on the yoke and the  $\frac{3}{4}$ " rod. Left-hand threads, when tightened, will not tend to untighten sucker rod connections.
- g) Tighten all bolts and connections except for the three bolts in the taper lock on the well cover that were left snug in an earlier step.
- h) Rotate the crank arm to bring water to the surface. The cam roller in the crank arm has been installed at the maximum stroke / rotation position which is at the end of the crank arm. This position describes or results in a cam roller rotation path of approximately six inches in diameter, resulting in a stroke of approximately six inches in length. Ideally, this six inch stroke should be in the center of the sixteen inch available length of pump cylinder. If the crank arm does not rotate freely, it is likely that the piston is not centered in the pump body and the piston is hitting either the bottom or top of the cylinder. There is one way to re-position the piston relative to the pump cylinder...by increasing or decreasing the length of the 12-1/2" PVC adaptor threaded into the bottom of the riser tube. (PVC slip coupling fitting included, but you must use locally-sourced PVC cement). We have provided a 1-1/4" slip coupler that can be used (if necessary) to shorten the PVC adaptor if for some reason the pump piston is operating too close to the top of the pump cylinder. Two of these adaptors and a short length of 1-1/4" PVC pipe can be used (if necessary) to lengthen the PVC adaptor if for some reason the pump piston is operating too close to the bottom of the pump cylinder.

## SECTION 6: PUMPING WATER. FINISHING TOUCHES

---

It will require about three rotations for each foot of water depth to get the water up to the pump head. 100 feet will require about 300 rotations. There is a very small bleeder hole about 3 feet below the pump head, in the top drop pipe. This takes about 15 minutes to drain and protects the pump against freezing. Each time you go out to pump after a period of pump inactivity, it will require about 10 to 12 rotations to get the water back to the pump head. The check valves in the pump cylinder allow a very small amount of leakage over time. Over several days or weeks, you may need to pump a few extra rotations to get the water back to the top.

### ADJUSTING AND SETTING UP THE PUMP

In this section we will be making adjustments to the force required to operate the pump, as well as completing the final steps of pump assembly.

a) It is now time to adjust the force required to operate the pump. The counterbalance has already been configured so that it takes five pounds of force (at a maximum) to raise the weight to its elevated position. We will use this fact to help us position the track roller bearing in the correct hole of the pin arm. Begin cranking the pump. After ten to twenty revolutions, water should begin pouring from the spout. The 180 degrees corresponding to the upstroke of the piston should feel as "hard" to crank as the 180 degrees corresponding to the elevation of the counter weight.

- ▶ If the 180 degrees of the upstroke of the piston is more difficult - the track roller bearing needs to be moved closer to the shaft
- ▶ If the 180 degrees of counterbalance elevation is more difficult - the track roller needs to be moved further from the shaft
- ▶ If the full revolution feels consistent - the roller bearing is positioned correctly

With the correct roller bearing position determined tighten roller bearing using Allen wrench.

**Be sure that the roller bearing is fastened securely.**

# SIMPLE PUMP ADA100 PARTS LIST

5/13/2009

NUMBER	DESCRIPTION	PRICE
<b>SEALS &amp; O-RINGS</b>		
O23	023 O-ring (100 bottom seat)	\$1.00
O29	029 O-ring (SS riser tube to pump head)	\$1.00
121	121 O-ring (rod gland to pump head)	\$1.00
626-212	100 U-cup seal for piston	\$5.00
626-210	U-cup seal for 3/4" diameter stainless rod	\$5.00
<b>MODEL 100</b>		
SIM043 Piston	100 piston	\$30.00
SIM043-1 Piston Seat	100 piston seat	\$15.00
SIM047 Piston Rod	3/8" diameter SS piston rod	\$30.00
	3/4" diameter SS ball	\$5.00
SIM040	100 SS pump cylinder	\$125.00
SIM044	100 SS bottom seat	\$40.00
626-212	100 U-cup seal for piston	\$5.00
<b>PVC FITTINGS</b>		
835-010	1" female NPT X 1" slip, schedule 80	\$7.00
436-010	1" male X 1" slip	\$1.25
436-168	1 1/4" male NPT X 1" slip	\$2.25
<b>DROP PIPE</b>		
D3-100RG	rod guides	\$4.00
D5-109DPT	drop pipe - top	\$15.00
D1-109DP	drop pipe	\$15.00
D2	sucker rod	\$20.00
<b>PUMP HEAD</b>		
SIM020 / P3	3/4" diameter top pump rod - left hand threads	\$85.00
SIM031	Rod Gland, nylon	\$35.00
626-210	U-cup seal for 3/4" diameter stainless rod	\$5.00
<b>ADA100</b>		
ADA100:125.40	125.40 1 1/4" X 10" schedule 40 PVC	1.00
ADA100:435012	435012 PVC 1 1/4" FNPT X 1 1/4" slip	2.00
ADA100:435020	435020 2" slip X 2" female NPT adapter	2.00
ADA100:437250	437250 2" X 1 1/4" slip X slip bushing, PVC	2.50
ADA100:4464K39	4464K39 3/4" 90 degree Elbow - Male NPT X Female NPT, 304SS	18.00

ADA100:450007	450007 3/4"male PVC plug	2.00
ADA100:91015A033	91015A033 Jam Nut 1/2-13	1.25
ADA100:91475A027	10-32 Lock Washer, SS	0.10
ADA100:91841A195	10-32 Hex Nut, SS	0.15
ADA100:SIMA01	SIMA01 Pump Head	200.00
ADA100:SIMA01A	SIMA01A Pump Head Spacer	20.00
ADA100:SIMA02	SIMA02 Riser Tube	55.00
ADA100:SIMA03	SIMA03 Drive Shaft	25.00
ADA100:SIMA04	SIMA04 Hand Crank Arm	40.00
ADA100:SIMA06	SIMA06 Bearing Housing	50.00
ADA100:SIMA07	SIMA07 Counterweight	65.00
ADA100:SIMA07A	SIMA07A Counterweight Shaft Clamp	25.00
ADA100:SIMA08	SIMA08 Upper Roller Mount	20.00
ADA100:SIMA09	SIMA09 Yoke - left hand threads	150.00
ADA100:SIMA10	SIMA10 6" Well Cover	100.00
ADA100:SIMA11	SIMA11 Split Flange	40.00
ADA100:SIMA12	Fafnir YA012RR Bearing	40.00
ADA100:SIMA13	SIMA13 Yoke Crank Arm	30.00
ADA100:SIMA14	SIMA14 8" well cover	100.00
ADA100:SIMA15	SIMA15 3/16" spacer for cam roller	2.00
ADA100:SIMA16	4830K196 304SS 4" X 3/4" nipple	10.00
ADA100:SIMA18	Safety Tool	20.00
ADA100:SIMA48	6308K46 Phenolic Rotating Handle with 1/2-13 thread	25.00
ADA100:SIMA49	1/2-13 X 4 SS all thread	6.00
ADA100:SIMA50	SIMA50 Enclosure with Cover, 10ga, powder-coated	350.00
ADA100:92196A626	3/8-16 X 1 1/4 SS Allen Head	2.00
ADA100:92196A585	5/16-18X1-1/4 SS Socket Head Cap Screw	1.00
ADA100:92196A583	5/16-18X1 SS Socket Head Cap Screw	1.00
ADA100:92311A576	5/16-18X3/8 SS Cup Point Socket Set Screw	.50
ADA100:nameplate	nameplate	5.00

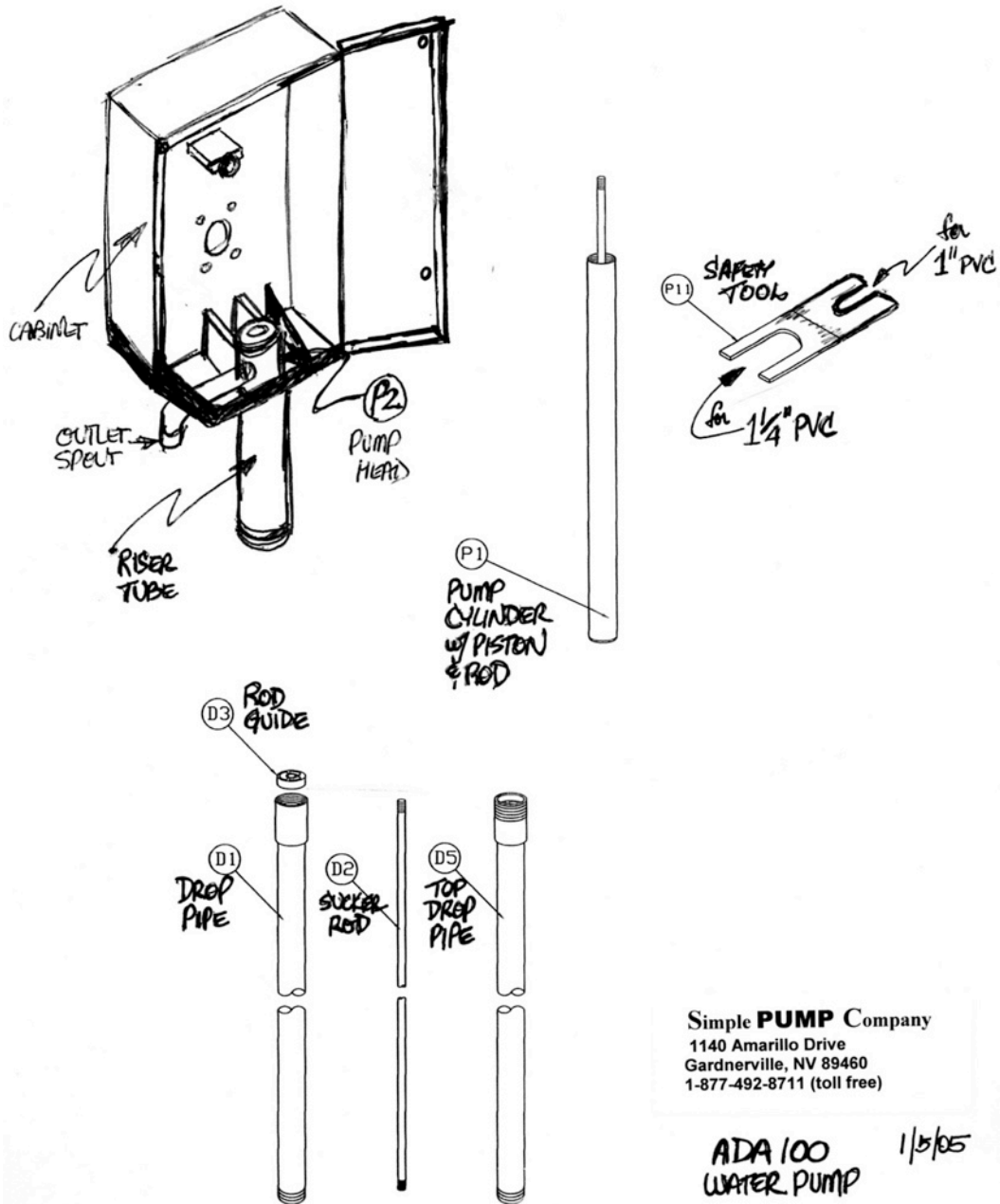

Simple **PUMP** Company  
 1140 Amarillo Drive  
 Gardnerville, NV 89460  
 1-877-492-8711 (toll free)

ADA 100  
 WATER PUMP

1/5/05

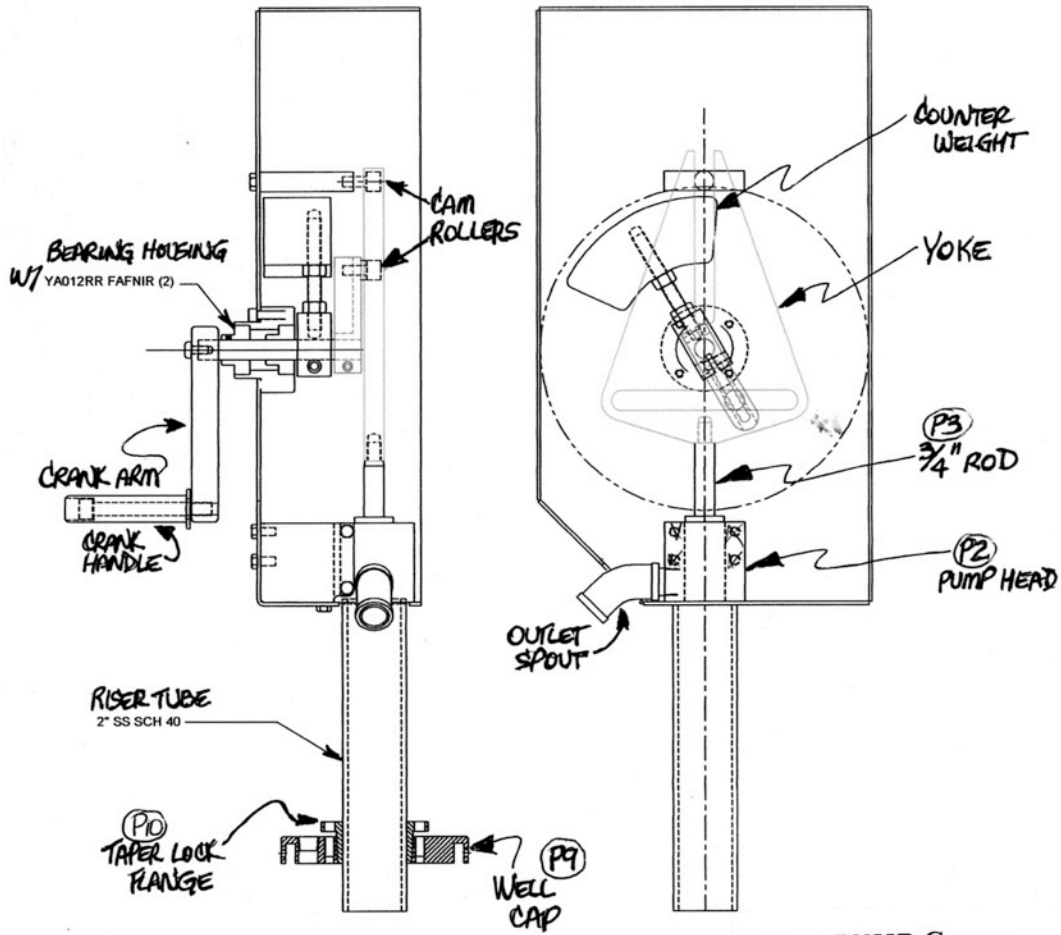

ADA/00  
 ADA WATER PUMP

Simple PUMP Company  
 1140 Amarillo Drive  
 Gardnerville, NV 89460  
 1-877-492-8711 (toll free)

1/5/05