

# **SNAP-FAN**



For Customer Service Please Call  
1.800.923.4901



# **SNAP-FAN**

**.COM**

## **Installation Instruction Manual**

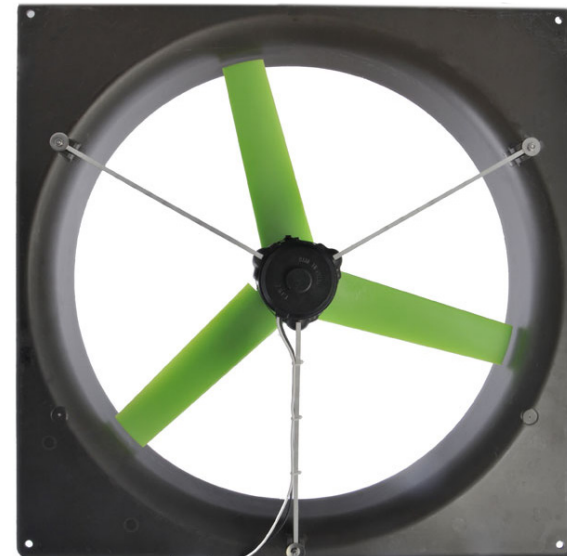

**Solar Powered  
Ventilation**

## Table of Contents

<b>Warranty.....</b>	<b>2</b>
<b>Product Support Information.....</b>	<b>3</b>
<b>Safety Information .....</b>	<b>3</b>
<b>Placement and Care Guidelines.....</b>	<b>4</b>
<b>Snap-fan Kit Components .....</b>	<b>5</b>
<b>Installation Instructions .....</b>	<b>6 - 14</b>
<b>Technical Specifications.....</b>	<b>15</b>
<b>Fan Mounting Hole Diameters .....</b>	<b>16 - 20</b>

## Manufacturers Warranty

SNAP-Fan warranties that all Snap-Fans are free from defect of workmanship and/or material for a period of two (2) years from the date of purchase. The two year manufacturer's warranty covers all Snap-Fan components with the exception of brushes which are designed to be replaced at the end of their service life. The SNAP-Fan motors are designed to operate at varying voltages. They perform best when powered by a solar module with a peak power point of 18VDC, and that is the voltage we warranty them at. Should any Snap-Fan be determined by SNAP-Fan to be defective, at the option of SNAP-Fan, the product will be replaced or repaired and returned to the customer free of defects. The customer is responsible for notifying SNAP-Fan within thirty (30) days of discovery of any defects. Disclaimer of Warranty and Limitations of Liability: Except as expressly set forth herein, this Snap-Fan is provided "AS IS" without warranty, expressed or implied including, but not limited to, all warranties are hereby expressly disclaimed. In no event shall SNAP-Fan be liable for the loss of profits, or indirect, special, incidental, consequential or other similar damages, including but not limited to any claim or demand arising out of the installation, existence, furnishing, or functioning of any of the Snap-Fans or use by any customer or third party of any product. In no event shall SNAP-Fan have any liability for any breach of warranty for improper installation of the Snap-Fan.

To the fullest extent allowed by law, SNAP-Fan liability to customers for all claims with respect to the Snap-Fan shall be limited to the lesser of:

- (1) The cost of the installation;
- (2) The cost of installing equivalent fan;
- (3) The cost of re-installing the Snap-Fan.

General: The contract contains all of the terms and conditions of the transaction between customer and SNAP-Fan. No representation, arrangement, or agreement not appearing herein shall be binding on SNAP-Fan. This contract may not be altered or modified by Customer, except in writing signed by an Office of SNAP-Fan. The contract shall be governed by the laws of the state of California. The prevailing party in any action brought pursuant to this contract shall be entitled to recover all costs of such action, including without limitation, attorneys' fees.

SNAP-FAN LLC.  
1150 Evergreen Rd. #3  
P.O. Box 1250  
Redway, CA 95560

## Product Support & Contact Information

The Snap-Fans are high efficiency solar direct ventilation fans designed to be used in ventilation fan applications. Using this equipment for any other purpose or in a manner not consistent with the operating recommendations within this manual will void the warranty and may cause personal injury.



SNAP-FAN LLC.  
1150 Evergreen Rd. #3  
P.O.Box 1250  
Redway, CA 95560  
1.800.923.4901

## Safety Information

**Caution:** The blades of the Snap-Fan spin at high rates of speed therefore extra precaution must be used when choosing a location to install your fan. With each installation site decision check to make sure the spinning fan blades are out of reach of humans and animals. OSHA requires finger guards for fans located less than eight (8) feet from the ground. For circumstances requiring fan installation less than 8 feet from the ground finger guards are available for purchase.



Occupational Safety and Health Administration (OSHA) requires finger guards at locations under eight feet from the floor.



Connect only to low voltage less than 35VDC power supply. If more than 18 VDC is applied VOID WARANTEE.



Follow all applicable electricity safety precautions and local codes.

## Placement and Care Guidelines

We are confident you will be happy with Snap-Fan's performance and durability. This fan will provide you with many years of service with little maintenance, provided a few simple precautions are adhered to:

### Proper Placement

Be sure to place the fan in a suitable location to maximize air movement. Typically Snap-Fans are installed close to a room's ceiling to both exchange and circulate warm interior air with cool air from outside.

### Static Pressure (in H<sub>2</sub>O)

Static Pressure refers to how much vacuum is created in an environment by removing the air by way of an exhaust fan. If the correct amount of 'free air' is available, the lower the static pressure will be, resulting in more cubic feet per minute (CFM) per watt. See technical specification on page 15.

### The Elements

Shelter your Snap-Fan from inclement weather and natural hazards such as, but not limited to, wind, water, rain, hail, dust, ice, snow and nesting birds. If you do not plan on using your Snap-Fan during wet, frozen winter months please remove Snap-Fan and store in a dry location until ready for use as long periods of moisture shortens the life span of the motor. Snap-fan must not be placed within 500 feet from saltwater environments as corrosion will prematurely wear out even the best of electronic equipment.

# SNAP-FAN KIT

Only qualified personnel should install or perform maintenance work on the exhaust fan and solar driver. We recommend that these appliances be installed in accordance with local building and electrical code requirements.

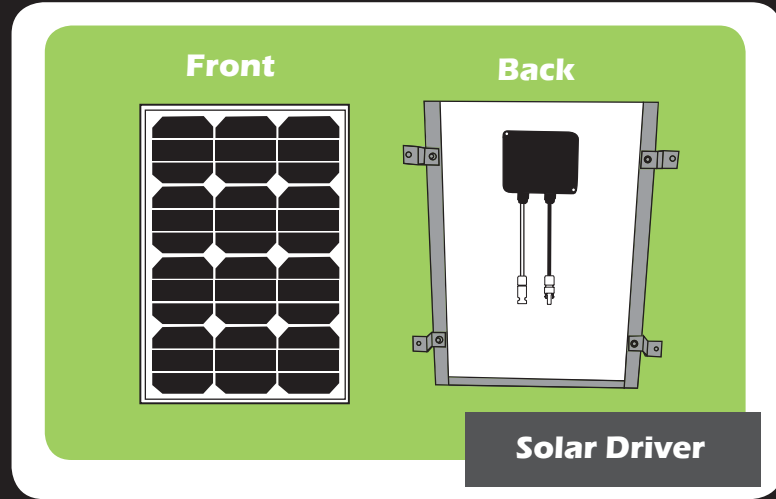
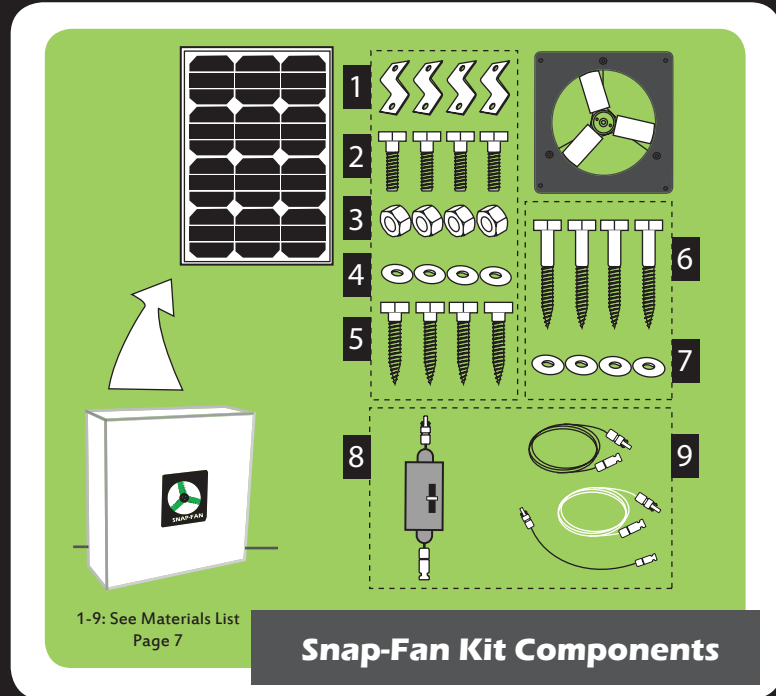

# CAUTION:

## SNAP-FAN

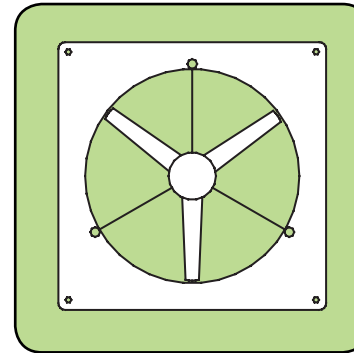

## SNAP-FAN MOTOR

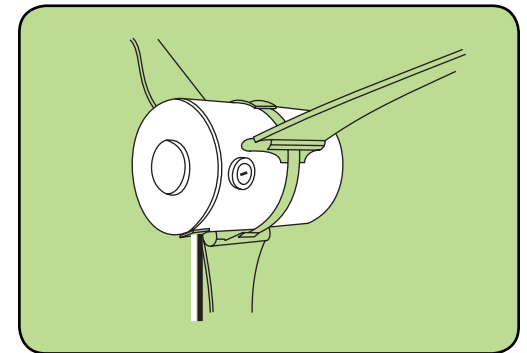

Only qualified personnel should install or perform maintenance work on the SNAP-Fan and SNAP-Fan Motor.



Shield from wet weather conditions.



Refer to installation and operation manuals before installing, servicing or operating this unit.



We recommend running motors on our solar driver at 18VDC as higher voltage/ampere on fan motors will decrease brush life.



Be aware of dangerously high DC voltages when connecting or disconnecting the SNAP-Fan from the Solar Driver.

\*We recommend covering the Solar Driver with a blanket before connecting or disconnecting SNAP-Fan from the Solar Driver.

# CAUTION:

## SOLAR DRIVER

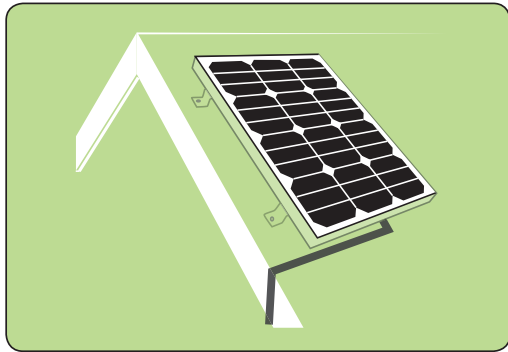

Only qualified personnel should install or perform maintenance work on the solar driver.



Refer to installation and operation manuals before installing, servicing or operating the solar driver.



FRAGILE: Glass surface to be handled with care. Non-repairable if broken.



Do not damage or scratch the rear surface of the solar driver. Non-repairable if scratched.



Do not handle or install solar driver when wet.



The solar driver produces electricity when exposed to light. DO NOT DISCONNECT UNDER LOAD. Follow all applicable electricity safety precautions.

## MATERIALS NEEDED FOR ASSEMBLY:

### Materials Included:

1. Z-Brackets to Mount Solar Driver: 4
2. Bolts for Z-Brackets: 4
3. Nuts for Z-Brackets: 4
- 4 & 7. Washers: 12
5. Wood Screws to Mount Solar Driver: 4
6. Lag Bolts to Mount Fan: 4
8. Breaker Box
9. Wires with MC 4 Couplers: 3

### Tools Required:

1. Screwdriver - Philips #2
2. Screwdriver - Flat head
3. Open End Wrench - 7/16"

# INSTALLING SNAP-FAN

## Location

1a

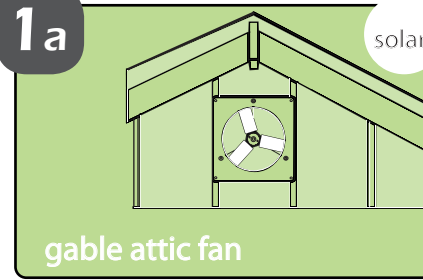

gable attic fan

1b

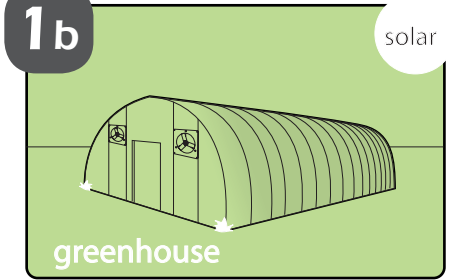

greenhouse

Choose a location to install your SNAP-fan. (Application not limited to examples above)

Exhausting hot air from the highest point possible is recommended.



Occupational Safety and Health Administration (OSHA) requires finger guards at locations under eight feet from the floor.

2a

### Build Frame

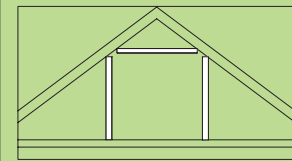

Frame Inside

### Cut Out Exterior

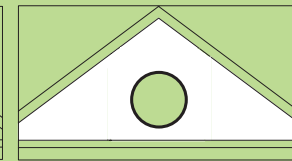

Exhaust Cut Out

### Install

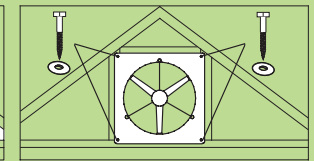

Fasten with #6 Lag Bolts and #7 Washer

Attic Gable

2b

### Build Frame

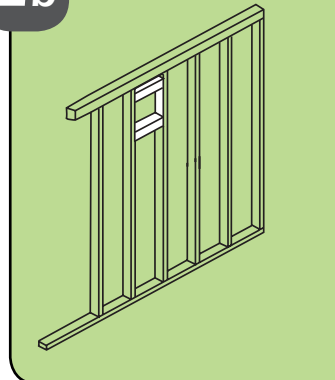

### Cut Out Exterior & Install

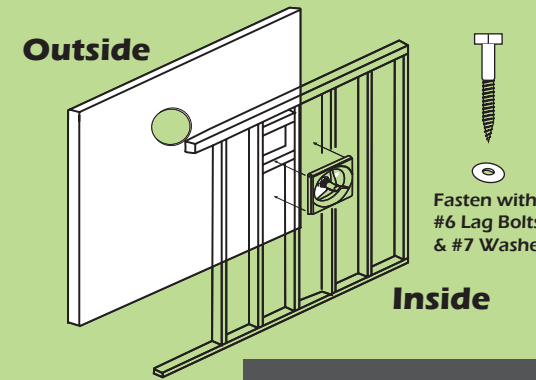

Fasten with #6 Lag Bolts & #7 Washer

Greenhouse Wall

If framing does not already exist in the original structure, it will need to be constructed. It is recommended that all structures be modified or constructed to code.

Once the frame for the fan is in place, cut a hole in the exterior surface so that air may be exhausted from the structure. See pages 17-27 for hole cut out dimensions. You are now ready to install the fan. Four lag bolts are included in your SNAP-Fan kit to fasten the fan to the frame. (Item #6 on page 5).

**DO NOT CUT AWAY ANY WOOD FRAMING FROM THE ORIGINAL STRUCTURE, AS IT MAY EFFECT LOAD BARING CAPACITY.**



Only qualified personnel should construct any new frame work necessary to house the Snap-Fan.

## Resulting Air Flow

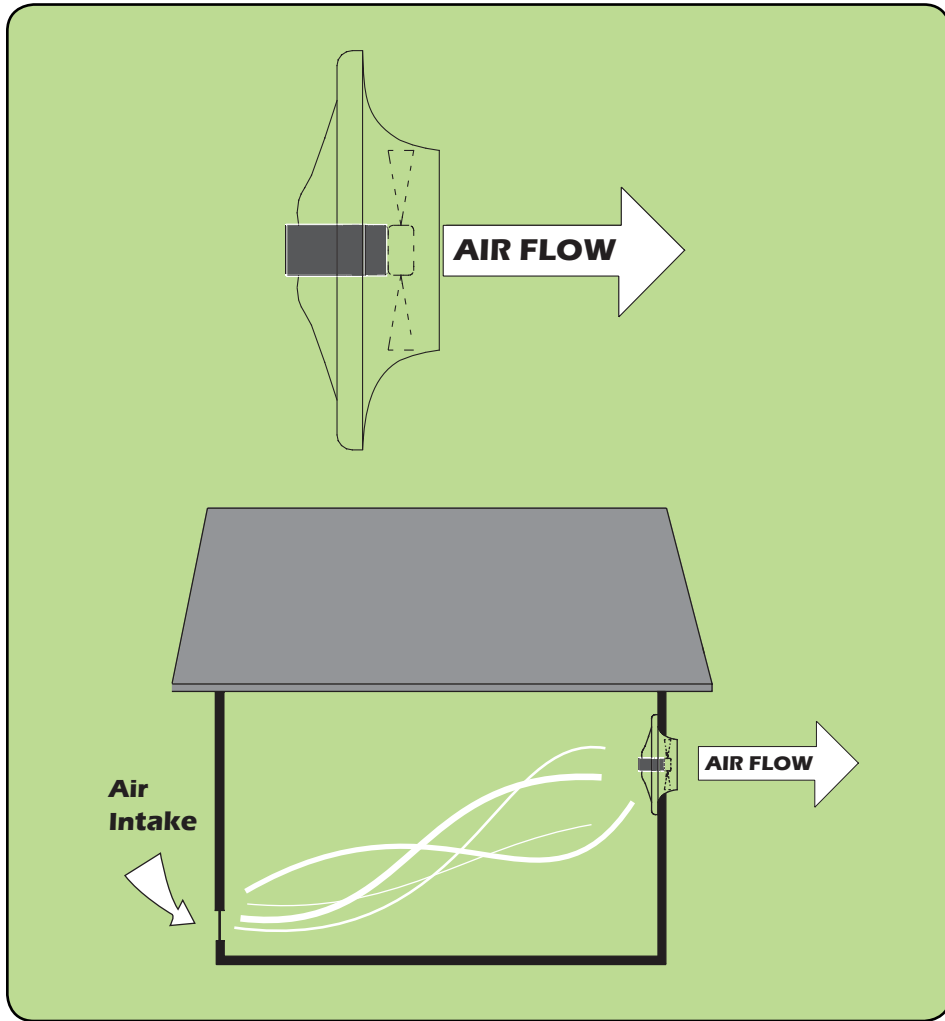

**You are now ready to install the solar driver.**

## INSTALLING SOLAR DRIVER:

### Location

1

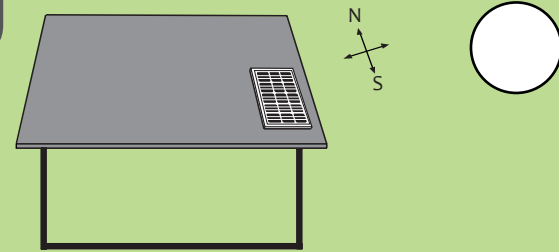

**UNSHADED SOUTHERN EXPOSURE IS IDEAL**

Begin by choosing a location for which to install your solar driver.

### Connect Z-Brackets to Solar Driver Racking

2

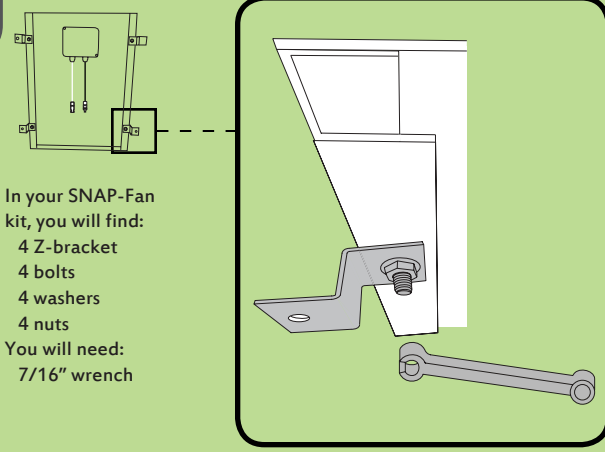

Fasten all four z-brackets to solar driver rack with nuts and bolts.

3

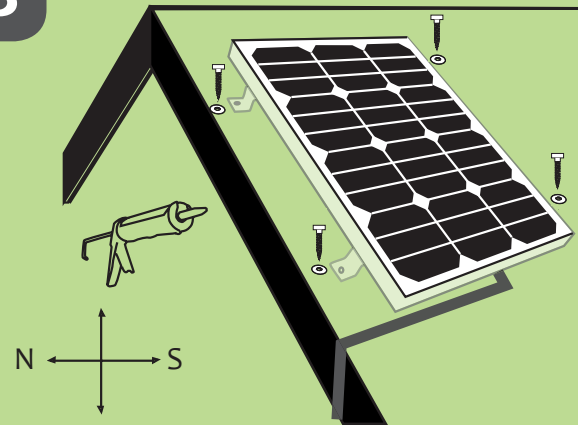

Find rafters and predrill holes in roof for #5 screws. Caulk over holes. Set Z brackets above calk, and fasten solar driver to roof with screws. Run the electrical cable across the roof to the SNAP-Fan.

# INSTALLING SOLAR DRIVER:

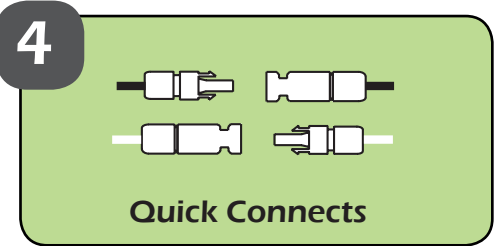

The 'Quick Connect' is located at the end of the wire connected to the Junction Box on the solar driver and on the back of the SNAP-Fan.

# WIRE INSTRUCTIONS:

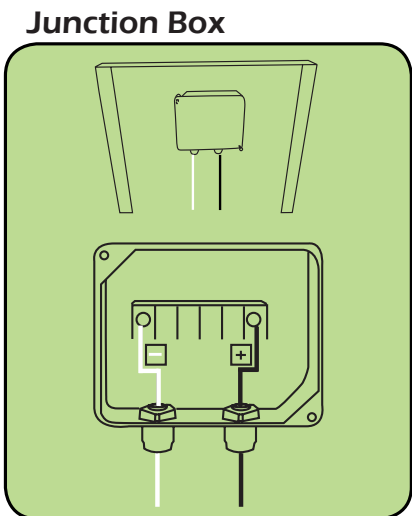
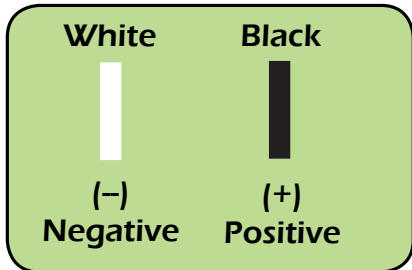

The Junction Box is located on the back of the solar driver. One black (+) and one white (-) cable will be attached to the junction box are capped with quick connects.

**!** Be aware of dangerously high DC voltages when connecting or disconnecting the SNAP-Fan from the Solar Driver.

## Wiring Diagram

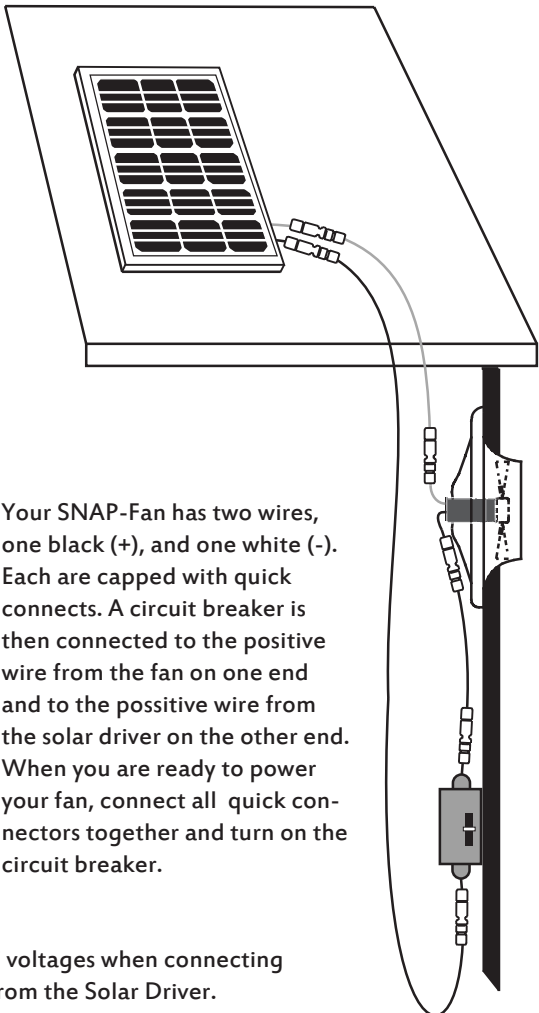

Your SNAP-Fan has two wires, one black (+), and one white (-). Each are capped with quick connects. A circuit breaker is then connected to the positive wire from the fan on one end and to the positive wire from the solar driver on the other end. When you are ready to power your fan, connect all quick connectors together and turn on the circuit breaker.

# WIRE INSTRUCTIONS:

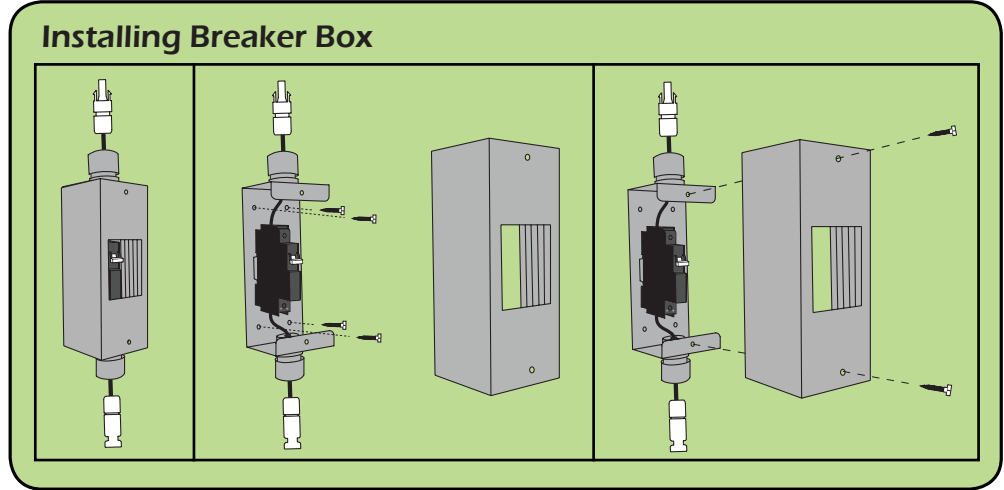

The breaker box included in the SNAP-Fan kit accomodates up to four MNEPV or MNEAC Din rail breakers. Fasten breaker box to a stud at a height that it is easily accessible. Remove cover plate and use four fasteners (not included) to attach to secure mounting surface. Once attached, replace cover. If additional fan circuits are needed, this is possible by adding circuit breakers and branch connectors.

# WIRING INSTRUCTIONS: 28" SNAP-FAN

## Branch Connector

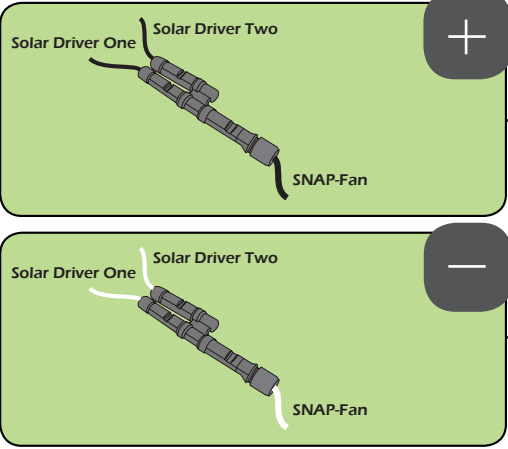

## Wiring Diagram

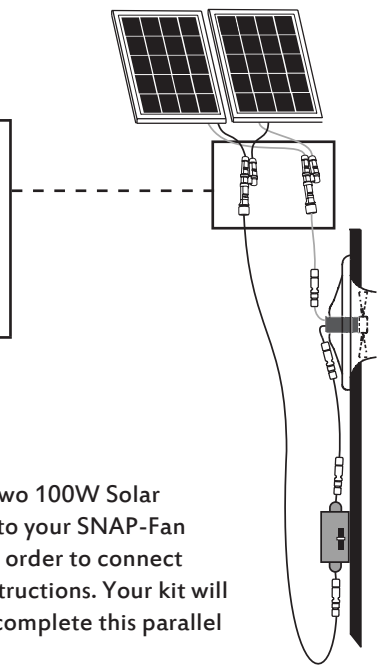

The 28" SNAP-Fan is designed to be powered by two 100W Solar Drivers. The most efficient way to provide power to your SNAP-Fan is to connect these two Solar Drivers in parallel. In order to connect these Drivers in parallel see page 15 for wiring instructions. Your kit will include two branch connector in order for you to complete this parallel connection.

# MOTOR MAINTENANCE:

## SNAP-FAN DC Motor: Replacing Brushes on 12" 16" & 20"

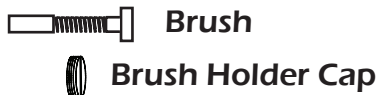
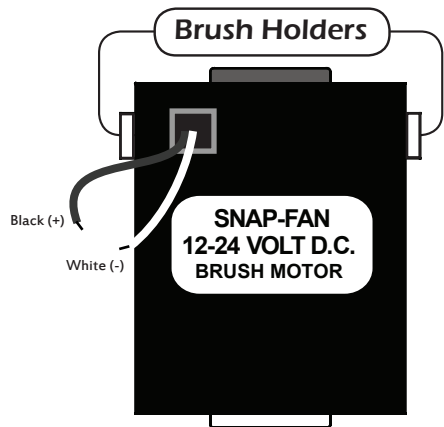

Brushes need to be replaced intermitently.

### To replace brushes:

1. Remove cap of brush holder with a flat head screw driver.
2. Insert new brushes.
3. Fasten cap back onto brush holder.

\*Brush holders are VERY fragile. When replacing brushes, take care not to over tighten the brush holder cap.

## SNAP-FAN DC Motor: Brush Install Diagram

BE CAREFUL TO NOT OVER TIGHTEN BRUSH HOLDER CAP

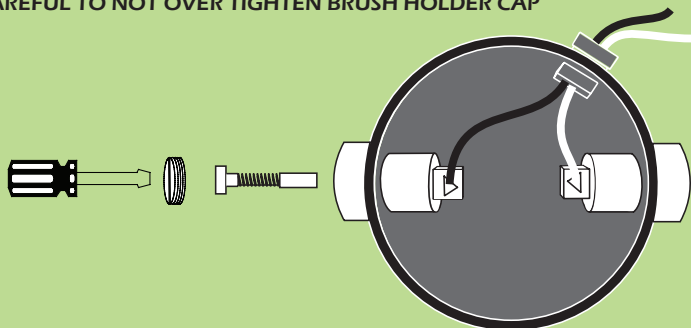

It is not necessary to disassemble motor in order to replace brushes

24" & 28" fans are 4 brush motors and have internal brushes that can be changed by qualified electritians.

# WIRING IN SERIES

## Series:

Series wiring connections are made at the positive (+) end of one module to thenegative (-) end of another module.

**Wiring in series increases the voltage [+], but the amperage [=] stays the same.**

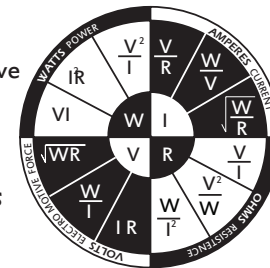

## OHM'S LAW

The law that for any circuit the electric current is directly proportional to the voltage and is inversely proportional to the resistance.

## Example for Wiring Solar Drivers in a Series:

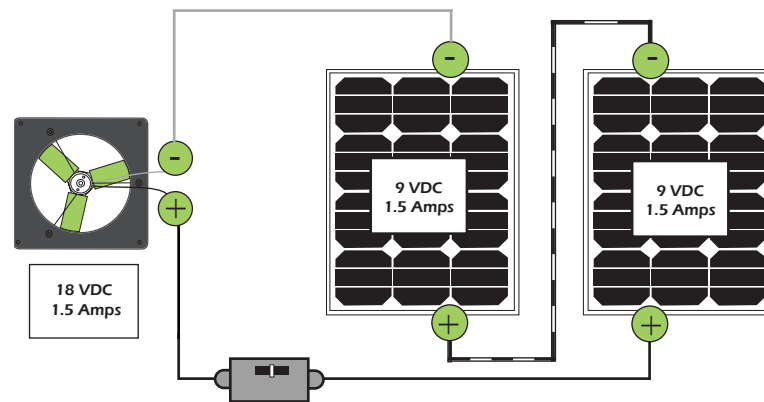

\*This wiring method is unlikely to be the most optimum set up for SNAP-Fans's because the motors run at such low voltages.

## Example for Wiring four 12" SNAP-Fans in two Series, connected in parallel:

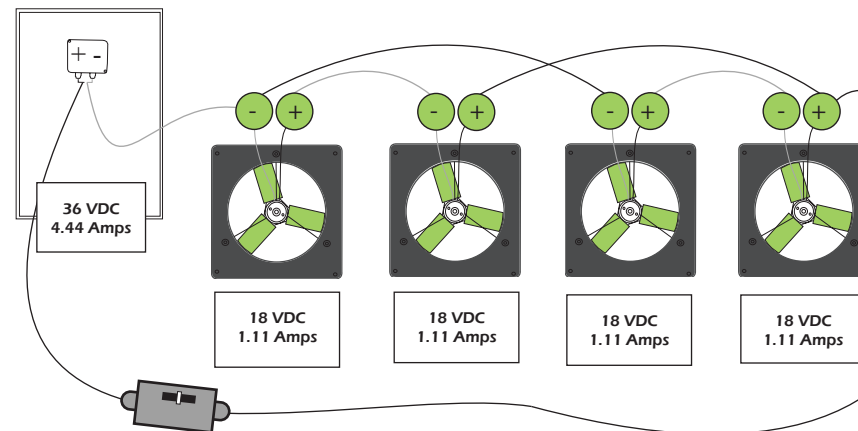

# WIRING IN PARALLEL

## Parallel Circuit:

Parallel wiring connections are made from the positive (+) to positive (+) terminals and negative (-) to negative (-) terminals between modules.

**Wiring in parallel increase the amperage [+], but the voltage [=] stays the same.**

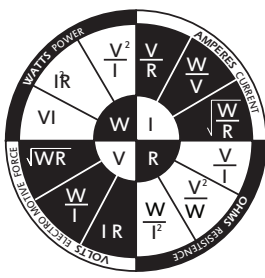

## OHM'S LAW

The law that for any circuit the electric current is directly proportional to the voltage and is inversely proportional to the resistance.

### Example for Wiring Solar Drivers in Parallel:

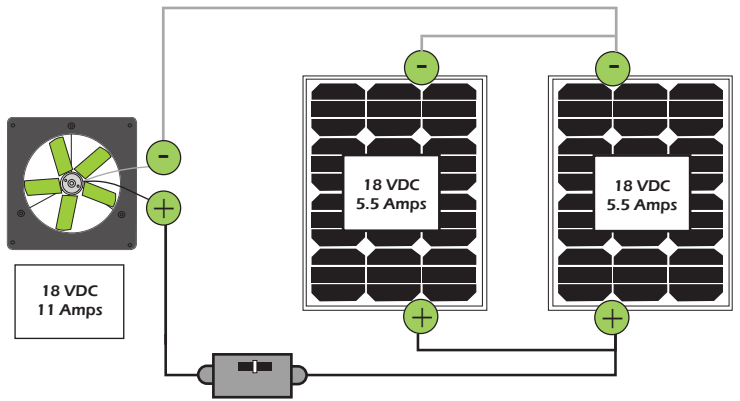

\*Recommended set up for 28" SNAP-Fan and two 100W Solar Drivers

### Example for Wiring four 12" SNAP-Fans in Parallel:

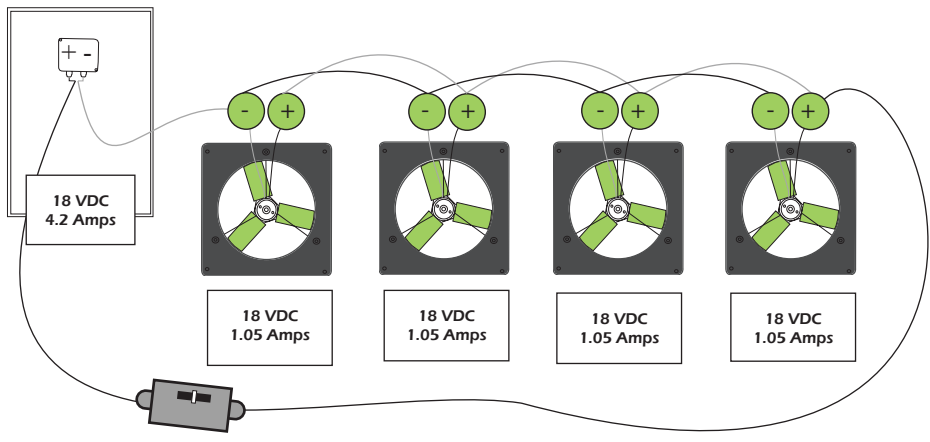

# TECHNICAL SPECIFICATIONS

All of our motors accept varying voltages from 1VDC – 40VDC.

**DO NOT EXCEED 40 VOLTS DC.** As higher voltage/amperage on fan motor will decrease brush life. We recommend running motors on our solar driver at 18VDC.

Below you will see the specific amperage draw for each motor at varying voltages and static pressures.

### 12" SNAP-FAN

	STATIC PRESSURE (IN H2O)	AIRFLOW (CFM)	RPM	AMPS	WATTS	CFM/WATT
24VDC	0.0	1030	1349	1.59	37	27.9
	0.05	930	1334	1.67	39	23.9
	0.10	810	1323	1.70	40	20.3
18VDC	0.0	830	1091	1.05	18	46.2
	0.05	680	1057	1.11	19	35.7
	0.10	360	1070	1.09	19	18.9
12VDC	0.0	580	774	.58	7	84.3
	0.05	250	762	.61	7	34.8
	0.08	140	732	.68	8	17.8

### 16" SNAP-FAN

	STATIC PRESSURE (IN H2O)	AIRFLOW (CFM)	RPM	AMPS	WATTS	CFM/WATT
24VDC	0.0	1720	1504	2.60	63	27.2
	0.05	1500	1447	2.72	65	23
	0.10	1310	1436	2.83	68	19.2
18VDC	0.0	1380	1211	1.73	31	44.5
	0.05	1110	1162	1.85	33	33.7
	0.10	890	1166	1.91	34	26.0
12VDC	0.0	980	876	0.98	12	84.7
	0.05	630	844	1.06	13	50.3
	0.08	260	841	1.15	14	19.0

### 20" SNAP-FAN

	STATIC PRESSURE (IN H2O)	AIRFLOW (CFM)	RPM	AMPS	WATTS	CFM/WATT
24VDC	0.0	2800	1445	4.13	101	27.7
	0.05	2500	1415	4.33	105	24.0
	0.10	2200	1391	4.45	108	20.5
18VDC	0.0	2200	1151	2.67	48	45.4
	0.05	1900	1121	2.86	51	36.3
	0.10	1500	1107	2.9	52	28.6
12VDC	0.0	1600	843	1.47	18	87.4
	0.05	1100	814	1.62	20	55.8
	0.10	500	823	1.55	19	28.8

### 24" SNAP-FAN

	STATIC PRESSURE (IN H2O)	AIRFLOW (CFM)	RPM	AMPS	WATTS	CFM/WATT
24VDC	0.0	3500	1358	5.07	122	29.0
	0.05	3100	1343	5.19	124	24.9
	0.10	2600	1335	5.22	125	20.9
18VDC	0.0	2800	1073	3.32	60	46.3
	0.05	2200	1057	3.44	62	34.8
	0.10	1700	1055	3.40	61	27.2
12VDC	0.0	1900	741	1.82	22	84.3
	0.05	1100	736	1.85	22	48.4
	0.08	300	744	1.75	21	12.1

### 28" SNAP-FAN

	STATIC PRESSURE (IN H2O)	AIRFLOW (CFM)	RPM	AMPS	WATTS	FM/WATT
24VDC	0.0	7810	1209	23.09	555	14.1
	0.05	7370	1197	23.40	564	13.1
	0.10	6940	1190	23.70	569	12.2
18VDC	0.0	6280	980	15.70	283	22.2
	0.05	5790	971	16.10	290	19.9
	0.10	5240	968	16.25	293	17.9
12VDC	0.0	4430	704	8.19	98	45.2
	0.05	3730	697	8.68	104	35.9
	0.10	2940	698	8.50	102	28.9

**Higher voltage/amperage on fan motor will decrease brush life. We recommend running motors on our solar driver at 18VDC.**

For higher voltage specifications see [www.snap-fan.com](http://www.snap-fan.com)

# FAN MOUNTING HOLE DIAMETER

## 12" SNAP-FAN

Use this guide to determine the size of the cut out hole necessary to mount your snap-fan.

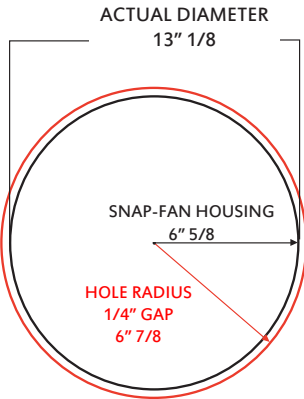
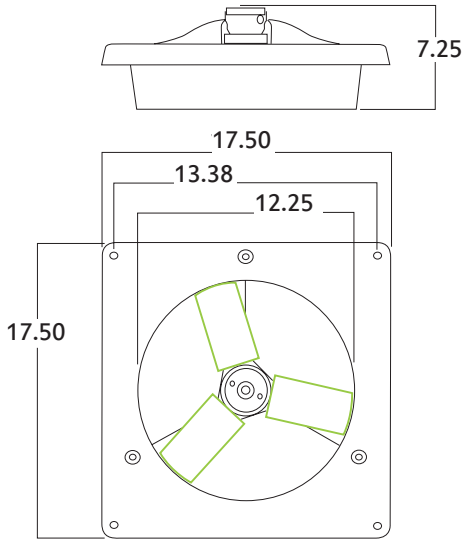

■ - Radius represents a hole 1/4" larger than the circumference of your SNAP-Fan's venturi housing.

**Make hole radius 6" 7/8**

# FAN MOUNTING HOLE DIAMETER

## 16" SNAP-FAN

Use this guide to determine the size of the cut out hole necessary to mount your snap-fan.

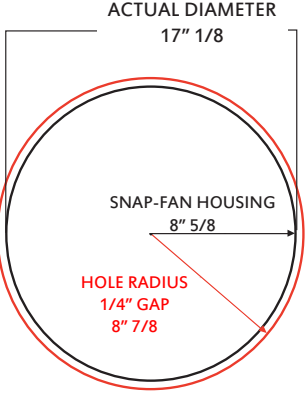
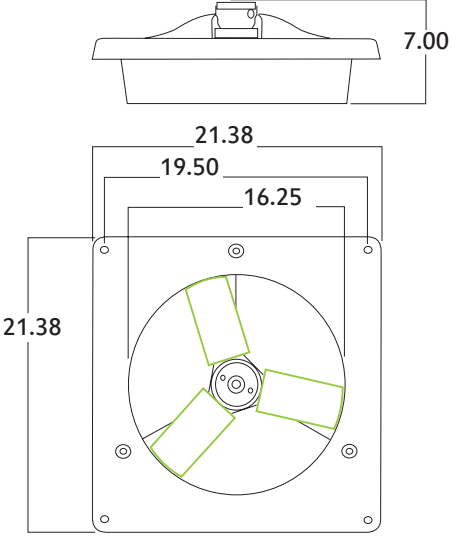

■ - Radius represents a hole 1/4" larger than the circumference of your SNAP-Fan's venturi housing.

**Make hole radius 8" 7/8**

# FAN MOUNTING HOLE DIAMETER

## 20" SNAP-FAN

Use this guide to determine the size of the cut out hole necessary to mount your snap-fan.

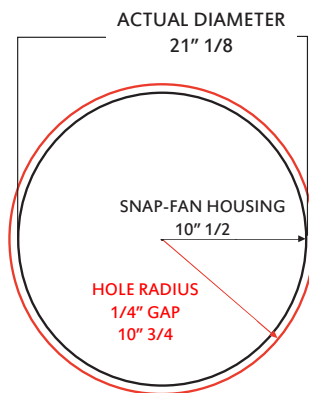
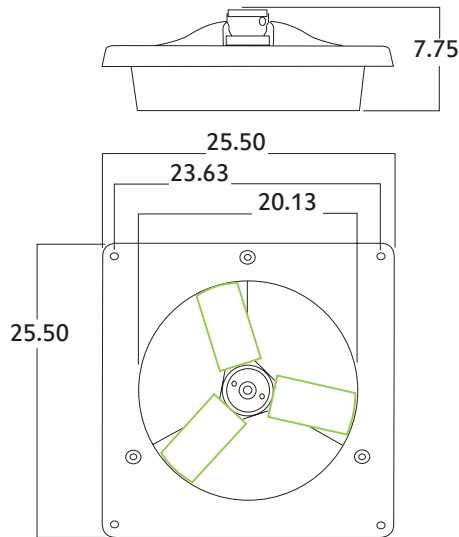

■ - Radius represents a hole 1/4" larger than the circumference of your SNAP-Fan's venturi housing.

**Make hole radius 10" 3/4**

# FAN MOUNTING HOLE DIAMETER

## 24" SNAP-FAN

Use this guide to determine the size of the cut out hole necessary to mount your snap-fan.

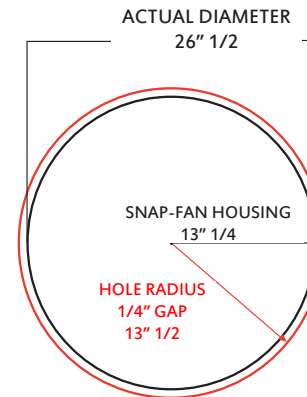
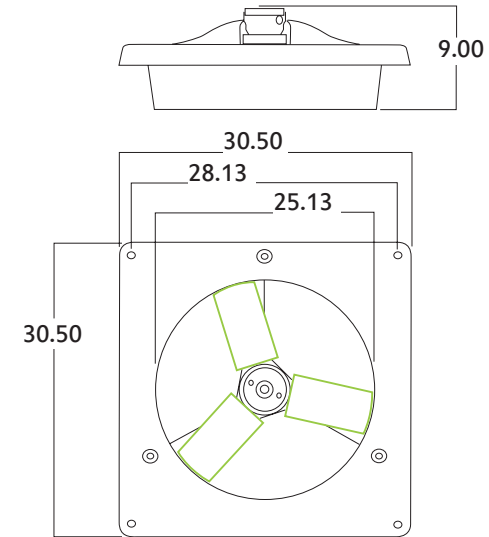

■ - Radius represents a hole 1/4" larger than the circumference of your SNAP-Fan's venturi housing.

**Make hole radius 13" 1/2**

# FAN MOUNTING HOLE DIAMETER

## 28" SNAP-FAN

Use this guide to determine the size of the cut out hole necessary to mount your snap-fan.

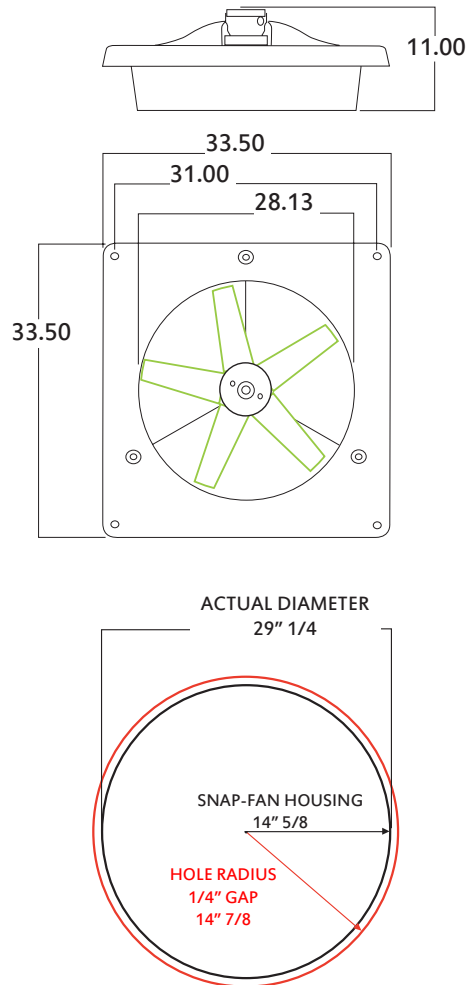

■ - Radius represents a hole 1/4" larger than the circumference of your SNAP-Fan's venturi housing.

**Make hole radius 14" 7/8**